





INFLATING & DEFLATING

1. Set the desired pressure.
2. Connect the hose to the tire, ensure the hose is connected securely. Air leaks will cause an error message to be displayed.
3. The pressure in the tire will be displayed.
4. The unit will inflate or deflate the tire to the set pressure. Periodically the process will stop and display the pressure in the tire.
5. If the pressure in the tire is less than 3 psi, 20 kPa or 0.2 bar the process will not commence until the **Flat Tire Only** button is pressed.
6. The scroll bar will indicate that the unit is inflating or deflating, see right. 
7. When the set pressure is reached, the display will flash and the unit will beep five (5) times. This will continue until the hose is disconnected; during this time the keypad will be disabled.

OPERATION

-  Reduces the set pressure.
-  Increases the set pressure.
-  Displays an alternative unit of measurement*

This button can be programmed to operate in one (1) of the following modes:

Default Unit Mode

Pressing and holding the button will momentarily display an alternative unit of measurement. When you release the key, the display will immediately revert back to the default unit of measurement. The pressure can only be set in the default unit of measurement.

Selectable Unit Mode

Pressing and releasing the button will display an alternative unit of measurement. The pressure can be set in any of the units of measurement.

*The units displayed on each machine will vary depending on the software that has been requested.

-  The **Flat Tire Only** button discharges up to five (5) bursts of air. Used when the pressure in the tire is less than 3 psi, 20 kPa or 0.2 bar.

EXTERNAL MOUNTING

1. Unpack the unit.
2. Hold the unit up on the wall and mark where the four (4) holes are to be drilled.
3. Secure the unit using suitable fasteners.
4. Connect the air supply to the unit.
5. Connect the power supply, refer to the rating label for the correct power requirements.

TROUBLESHOOTING

PROBLEM	POSSIBLE CAUSE	SOLUTION
No display.	No power supply.	Check power supply.
The inflation process does not commence, even when the pressure is set and the hose is connected to the tire.	The hose connector is faulty. The tire is deflated below 3 psi, 20 kPa or 0.2 bar.	Replace the hose connector. Press 
The display will not move or is stuck on a particular value.	The faceplate is damaged	Replace the faceplate.
The unit deflates very slowly.	The muffler on the valve block is blocked.	Remove and clean the muffler.
The unit no longer beeps.	The beeper is damaged.	Replace the beeper.
The inflation process commences but does not complete.	Low or nil supply pressure.	Check the air compressor supply pressure.
ER1	Unstable pressure, faulty hose connector	Replace the hose connector.
ER2	Unstable pressure, faulty hose connector. Incorrect supply pressure. Inflate & Deflate valve connections are reversed.	Replace the hose connector. Check the air compressor supply pressure. Check the valve connections on the PCB.
ER3	Low or nil supply pressure.	Check the air compressor supply pressure.
ER4	Initial or final pressure is too high, exceeding the maximum pressure by more than 20 psi, 140 kPa or 1.4 bar.	Disconnect hose connector, reset processor by switching off the power for a minimum of 5 seconds. If error message reappears replace PCB.
ER5	Low supply voltage.	Check power supply. The message will clear when the correct voltage is restored.
ER6	Program or PCB error.	Reset machine by switching off the power for a minimum of 5 seconds. If error message reappears replace PCB.
ER8	Calibration error.	Unit requires calibration, contact your local distributor service agent.
ER9	Calibration error.	Reset machine by switching off the power for a minimum of 5 seconds. If error message reappears replace PCB.

VOLUME ADJUSTMENT

- Turn the unit off.
- Press and hold the decrease and **Flat Tire Only** buttons.
- Turn the unit on, VOL will be displayed.
- Adjust the volume using the increase and decrease buttons.
- To store the setting, press the **Flat Tire Only** button. Further changes can be made by repeating the above procedure.

PART NO.

89XDA

QUAN

PART NUMBER

DESCRIPTION

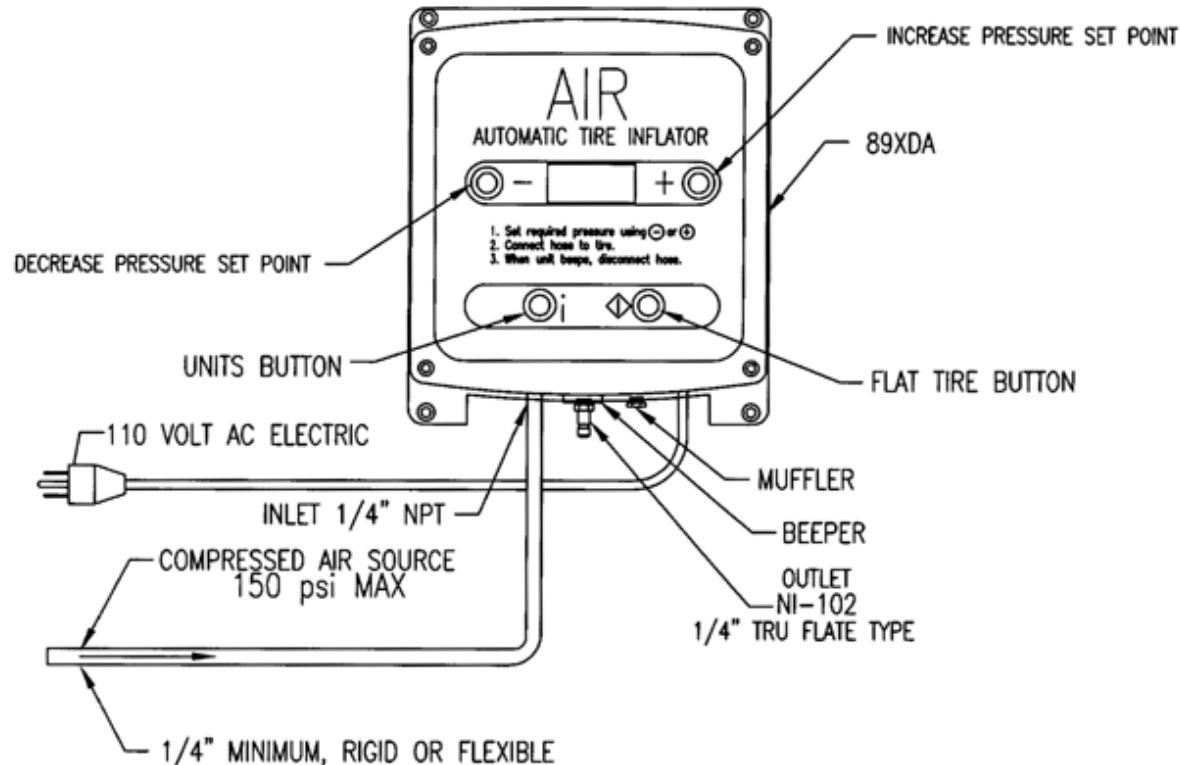

NOTE:

ALL COUPLERS AND NIPPLES ARE 1/4" TRU FLATE TYPE
AIR CHUCKS USED WITH INFLATOR MUST BE OPEN DESIGN

WARNING:

ALWAYS FOLLOW THE TIRE MANUFACTURER'S
RECOMMENDED INFLATION PRESSURES

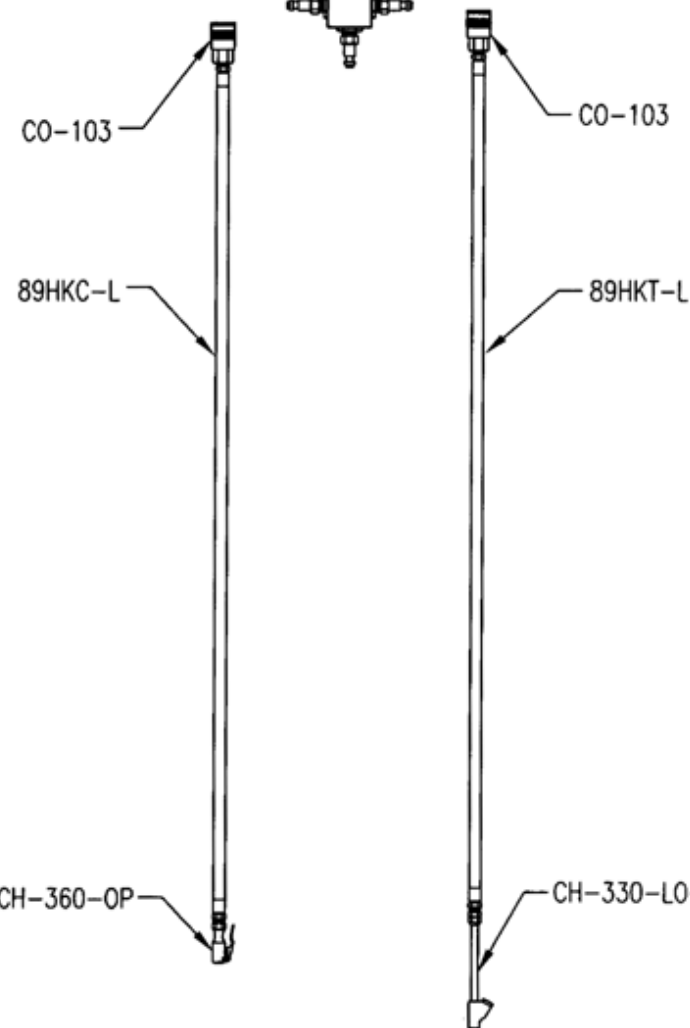
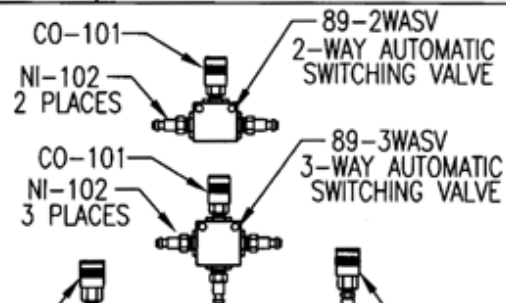

		SCALE NONE	AUTOMATIC TIRE INFLATOR
DRAWN	C'KED	APPROVED	
9/4/2003			PART NO. 89XDA
HALTEC			